

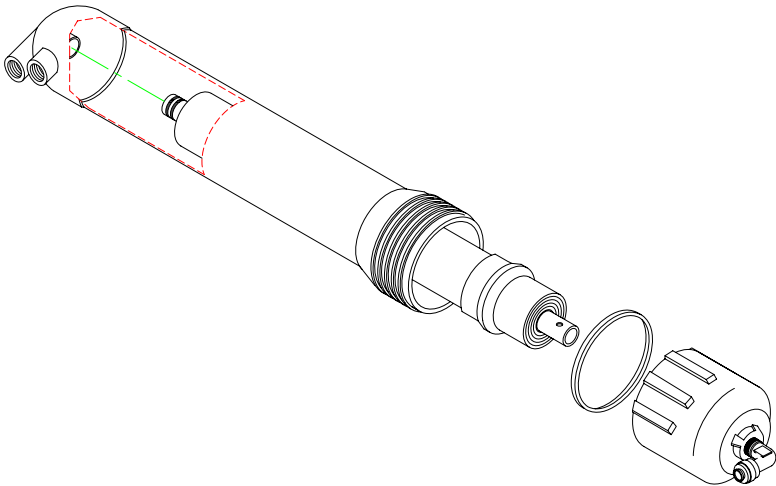

RO Membrane Replacement Guide



MEMBRANE WARNING: All SpectraPure RO membranes, once wetted, must remain moist. It is the customer's responsibility to inspect the membrane upon receipt and maintain adequate moisture.

Replacement membranes should be kept in the sealed impermeable shipping bag and in a refrigerator until use. The membrane may be kept there for up to 1 year. (DO NOT FREEZE)

REV 08-23-2013

*Visit us on the web at www.spectrapure.com
or Call us toll-free at 1-800-685-2783*

TABLE OF CONTENTS:

System Maintenance

RO Membrane Replacement	3-6
-------------------------------	-----

System Startup

Measuring the Concentrate to Purified Water Ratio	8
---	---

Flow Restrictor Removal, Adjustment & Replacement	9-11
---	------

Production Rate

Testing the Quality of the Membrane	12-13
---	-------

Membrane Testing

System Troubleshooting Guide	14
------------------------------------	----

Membrane Troubleshooting Guide	14
--------------------------------------	----

System Care

Tips for Long Membrane Life	15
-----------------------------------	----

Choosing a Mounting Location	15
------------------------------------	----

Warranty, Terms and Conditions	16
---	----

Copyright © 1997-2013 by **SpectraPure® Inc.**
ALL RIGHTS RESERVED

No part of this publication may be reproduced, stored in a retrieval system, or transmitted in any form or by any means, electronic, mechanical, photocopying, recording or otherwise without the prior written permission of SpectraPure Inc.

RO MEMBRANE REPLACEMENT:

1. Turn off the water supply to the RO system. Place the system where the membrane housing is easily accessible.
2. Remove the black tubing from the membrane feed push fitting by depressing the collar on the fitting with your thumb and pulling the tubing from the push fitting. Remove the blue and yellow tubings in the same manner. (Do not lose the flow restrictor that is inside the yellow line) If the flow restrictor gets caught in the fitting, pry the collar out and then remove flow restrictor.
 - a.) Firmly depress and hold the push fitting collar down with your thumbnail.
 - b.) While the push fitting collar is depressed, pull the tubing straight out of the push fitting. Once the tubing is removed, release the collar.

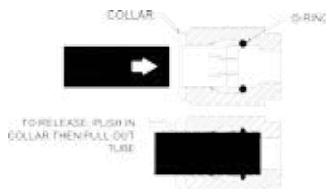

3. Lift the membrane housing from the retention clips.
4. Unscrew the membrane housing lid. This may require two people or use a strap wrench.
5. Use a pair of pliers to grasp the membrane stem and pull the membrane from the housing (Fig. A).
6. Remove the black cap housing O-ring. Wash the empty housing with soapy water. Rinse thoroughly with hot, clean water.

(continued on page 5)

Fig. A: Removing the Membrane Element

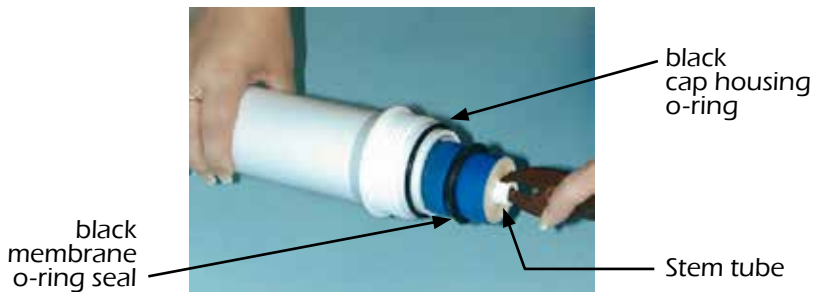

SpectraPure®

Note! If you are replacing a membrane in a system from another manufacturer with a SpectraPure membrane, you must follow THEIR procedure for adjusting their flow restrictor, or purchase the proper flow restrictor from SpectraPure, Inc.

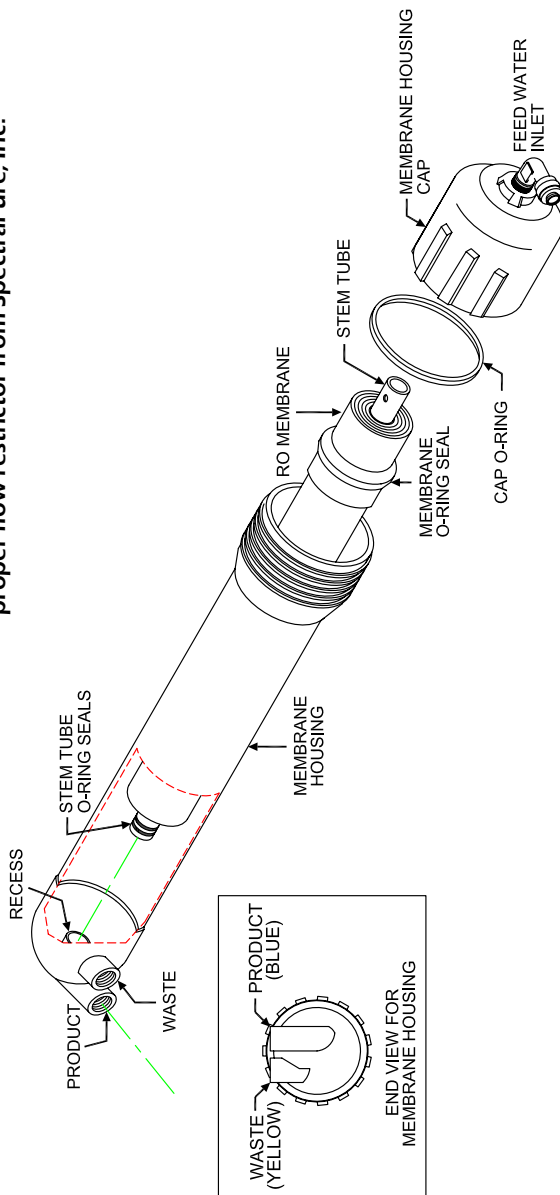

7. It is good practice to apply a small amount of waterproof grease to the two small Stem Tube O-ring Seals.
8. Insert new membrane into the housing, with the double O-ring end first (Fig.B). The tube must fit into the recess (page 4) at the bottom of the membrane housing. When the membrane is aligned with the hole, firmly push the membrane into the hole until it bottoms out.

Fig. B: Inserting the New Membrane Element

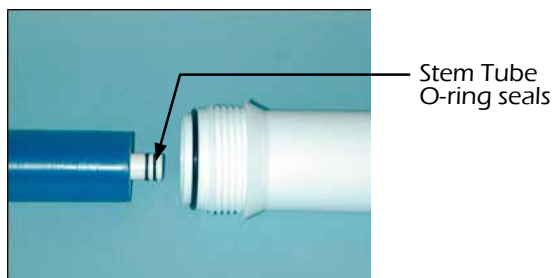

9. Place the black housing cap O-ring on the housing rim and carefully screw the lid back on to the base.
10. Reconnect the black tubing to the membrane feed push fitting by pushing the tube straight into the fitting. Lightly tug on the line to assure a good seal.

NOTE: If you have a dual-membrane system, perform steps 2 thru 9 on the second membrane now.

Fig. C: Membrane Housing

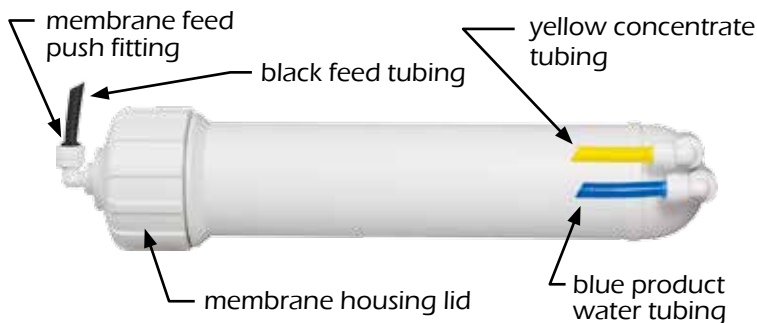

11. Reconnect the blue and yellow tubing to the membrane feed push fitting by pushing the tube straight into the fitting. Lightly tug on the line to assure a good seal. (Make sure that the flow restrictor is inside the yellow line).

(continued on next page)

SpectraPure®

12. Put the yellow concentrate tubing and the blue product water tubing in the drain.
13. If there are DI cartridges installed in this system, remove them and screw the empty housings back on. Don't run flush water through the DI resin.
14. Turn on the system water supply.
15. **If you are replacing your current membrane with a different size membrane**, you will need to remove your old flow restrictor and replace it with the new one. Then, follow the adjustment procedure for the new flow restrictor as shown on pages 9-10.

WARNING: Check the system to ensure that all fittings are tight and leak-free before leaving the system unattended.

NOTE: It is recommended that a new membrane be run to the drain for one hour to properly hydrate the membrane and flush any manufacturing residue before collecting purified water for use. Then replace the DI cartridges if you removed them earlier. If the unit is not used for several days, run the system for at least 10 minutes before collecting any water.

SpectraPure® Inc. assumes no responsibility for water damage due to leaks. It is the user's responsibility to determine that the system is leak-free.

SpectraPure®

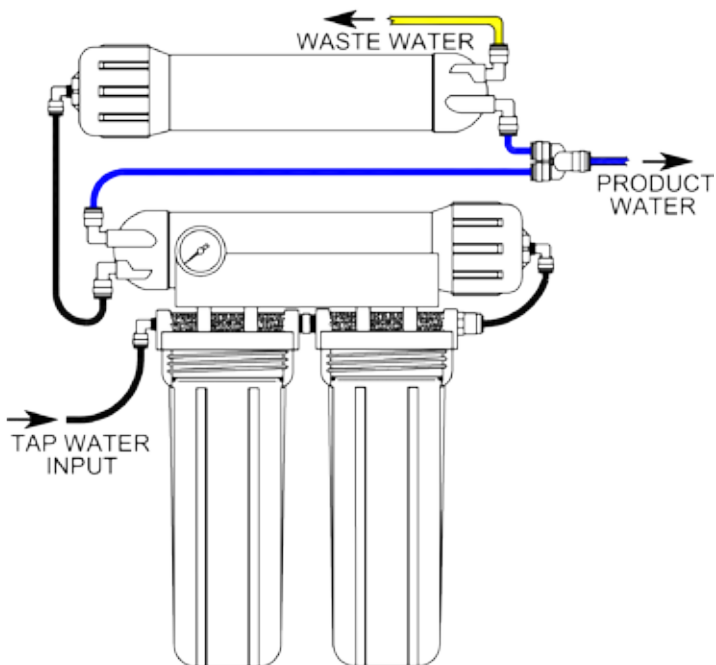
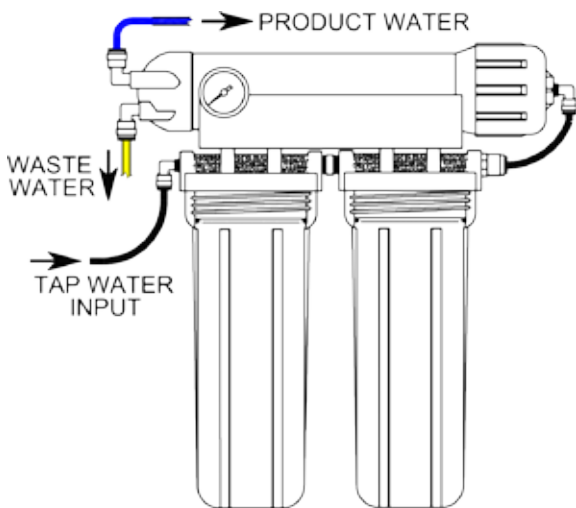

MEASURING WASTE TO PRODUCT WATER RATIO:

This procedure will assure you of maximum life and reliability of your SpectraPure System. *Failure to perform this procedure can permanently damage the membrane and will void Warranty.*

In order to maximize the life of your SpectraPure RO Membrane, you may need to adjust the ratio of the concentrate to purified water. If not enough concentrate is allowed to flow past the membrane during operation, the impurities will precipitate out on the membrane surface, clogging the RO Membrane. To keep this from happening, the Concentrate to Purified Water Ratio must be checked and adjusted in order to compensate for pressure and temperature variations that exist in all water supplies. The flow rate of the concentrate should be a minimum of 3X the product flow rate. (3X to 6X is an acceptable concentrate flow rate.)

Procedure:

1. Collect product water (blue tubing) into a measuring cup for one minute (Measure the collected amount in milliliters). Do the same with the waste water (yellow tubing):

WASTE (YELLOW) IN MILLILITERS _____

DIVIDED BY

PRODUCT (BLUE) IN MILLILITERS _____

The resultant is the Concentrate to Product Ratio

(Although not needed in this procedure, the daily product flow rate in Gallons per Day (GPD) can be calculated to be equal to the product flow rate times 0.38).

2. **If ratio is less than 3:1**

Disconnect yellow drain line from the membrane housing and remove flow restrictor (Fig D on page 10). Use the appropriate Waste to Product ratio chart (Fig E on page 11) to determine how long to cut the flow restrictor in order to obtain a 4:1 ratio. The shorter the flow restrictor, the more waste water.

Example: *If you have a 90 GPD unit (FR-90), and your product flow is 175 ml/.min, then the flow restrictor needs to be cut to a total length of 6 inches (15.2 cm).*

3. **If ratio is greater than 6:1**

flow restrictor requires replacement (Please contact SpectraPure Inc).

This completes the procedure.

FLOW RESTRICTOR REMOVAL, ADJUSTMENT AND REPLACEMENT:

NOTE: *Be sure to use the correct flow restrictor for the membrane you are replacing. See "Choosing the Correct Flow Restrictor on Page 10"*

1. Locate the yellow concentrate tubing. Remove the tubing from its push fitting at the membrane as shown on page 3.
2. Carefully remove the flow restrictor assembly, now visible as a plastic insert in the end of the yellow tubing (Fig. D on page 10). You may use an object such as a dull knife to help pry the flow restrictor insert from the end of the tubing. The entire flow restrictor (consisting of the insert collar and thin capillary tubing) may then be gently extracted.

NOTE: **Take care not to crush or otherwise damage the delicate capillary tubing.**

3. Refer to the Flow Restrictor Tables (Fig. E on page 11). Find the table that represents the Flow Restrictor Assembly for the system that you have. Find the **product concentrate flow rate** in the left-hand column and the **length of the flow restrictor** in the right-hand column.

Example: If your Flow Restrictor Assembly is for a 90 GPD Membrane and the **product flow rate** is 170 ml/Min, then the flow restrictor length should be cut to 6.5 inches (16.5 mm). 170 is about halfway between 164 (7 in.) and 175 (6 in.).

4. Using a new single-edge razor blade, carefully measure and then cut the flow restrictor to the total length indicated. If your tap water has a TDS reading of less than 250, cut the FR a couple of inches longer than indicated.
5. Reinsert the flow restrictor assembly into the yellow tubing and firmly reseal the insert into the end of the yellow tubing by carefully pressing on the insert with your thumbnail. Care should be taken not to crush or otherwise damage the end of the capillary tubing protruding from the end of the insert.
6. Reinsert the yellow tubing into its push fitting in the RO membrane as follows:
 - a.) Moisten the O-ring seal inside the concentrate outlet fitting by dripping a few drops of clean water into the fitting.
 - b.) Grasp the yellow tubing near the flow restrictor end, and insert the tubing into the push fitting. Push the tubing into the fitting until resistance is felt, approximately 1/2 inch (12.7 mm). The tubing is now resting on the O-ring seal inside the fitting.
 - c.) Firmly push the tubing approximately an additional 1/4 inch (6.35 mm) further into the fitting to completely seat the line into the fitting and O-ring seal.

SpectraPure®

7. Turn on the system water supply and check for leaks prior to further use or testing. If a leak is observed, you may not have pushed the yellow tubing into the push fitting far enough to seal the tubing against the O-ring. Turn off the system water supply and reseal the tubing as described above.

Fig. D: Flow Restrictor Assembly

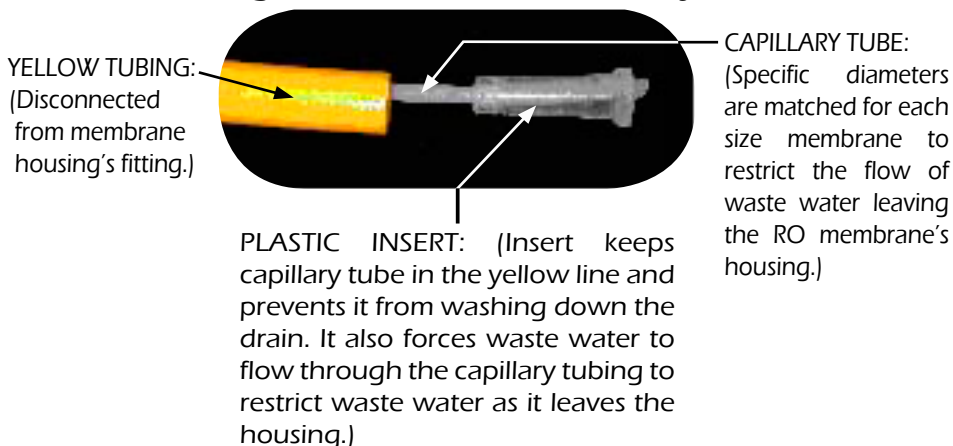

Choosing the Correct Flow Restrictor:

Make sure you have the correct Flow Restrictor Assembly for your Replacement RO Membrane. See the chart below for acceptable combinations of SpectraPure RO Membranes and SpectraPure Flow Restrictor Assemblies. Flow Restrictor Assemblies are shipped with extra length to accommodate low water temperatures and pressures.

WARNING: Failure to adjust the Flow Restrictor can permanently damage the membrane and will void the prorated Membrane Warranty.

GPD (lpd) Rated Membrane	Use Flow Restrictor Assembly
40 (151)	FR-40
60 (227)	FR-60
90 (340)	FR-90
180 (680)	FR-180

**Fig. E: Flow Restrictor Charts
(For 4:1 Concentrate to Product Ratio)**

FR-25 & FR-40 (RED)

PRODUCT RATE		CUT TO LENGTH	
ml/min	gpd	in.	cm.
110	42	1	2.5
84	32	2	5.1
75	29	3	7.6
69	26	4	10.2
63	24	5	12.7
60	23	6	15.2
55	21	7	17.8
51	19	8	20.3
47	18	9	22.9
45	17	10	25.4
44	17	11	27.9
42	16	12	30.5
40	15	13	33.0
39	15	14	35.6
38	14	15	38.1
37	14	16	40.6

FR-60 (ORANGE)

PRODUCT RATE		CUT TO LENGTH	
ml/min	gpd	in.	cm.
158	60	1	2.5
130	49	2	5.1
123	47	3	7.6
110	42	4	10.2
99	38	5	12.7
94	36	6	15.2
93	35	7	17.8
88	33	8	20.3
84	32	9	22.9
79	30	10	25.4
76	29	11	27.9
74	28	12	30.5
71	27	13	33.0
68	26	14	35.6
66	25	15	38.1
66	25	16	40.6

FR-90 (YELLOW)

PRODUCT RATE		CUT TO LENGTH	
ml/min	gpd	in.	cm.
269	102	1	2.5
233	88	2	5.1
213	81	3	7.6
198	75	4	10.2
183	69	5	12.7
175	67	6	15.2
164	62	7	17.8
154	58	8	20.3
148	56	9	22.9
141	54	10	25.4
136	52	11	27.9
133	50	12	30.5
129	49	13	33.0
128	48	14	35.6
124	47	15	38.1
124	47	16	40.6

FR-180 (GREEN)

PRODUCT RATE		CUT TO LENGTH	
ml/min	gpd	in.	cm.
490	186	1	2.5
460	175	2	5.1
430	163	3	7.6
400	152	4	10.2
379	144	5	12.7
356	135	6	15.2
344	131	7	17.8
326	124	8	20.3
311	118	9	22.9
300	114	10	25.4
289	110	11	27.9
281	107	12	30.5
270	103	13	33.0
263	100	14	35.6
259	98	15	38.1
256	97	16	40.6

TESTING THE QUALITY OF THE MEMBRANE:

Membrane Output Calculation

Membranes produce the rated gallons per day (GPD) at 60 psi (4.1 bars) operating pressure, 77°F (25°C) operating temperature and 500 ppm total dissolved solids.

Membrane output gallons per day (GPD) depends on operating pressure, water temperature and the ppm TDS in the feed water.

$$\text{Expected GPD} = \text{Rated GPD} \times \text{PCF} \times \text{TCF}$$

PCF is the pressure correction factor

TCF is the temperature correction factor

Calculation of Pressure Correction Factor (PCF): The output (GPD) from the membrane is directly proportional to the applied pressure.

NOTE: The membrane is rated to produce the rated GPD at 60 psi. For any pressure other than 60 psi the output GPD is multiplied by the PCF.

$$\text{PCF} = \text{Line Pressure (in psi)} \div 60$$

Calculation of Temperature Correction Factor (TCF): The output (GPD) also decreases with decrease in temperature. This is because water viscosity increases with decrease in water temperature.

Temperature Correction Factor Table (TCF)

°F/°C	TCF	°F/°C	TCF	°F/°C	TCF
41.0/5	0.521	59.0/15	0.730	77.0/25	1.000
42.8/6	0.540	60.8/16	0.754	78.8/26	1.031
44.6/7	0.560	62.6/17	0.779	80.6/27	1.063
46.4/8	0.578	64.4/18	0.804	82.4/28	1.094
48.2/9	0.598	66.2/19	0.830	84.2/29	1.127
50.0/10	0.620	68.0/20	0.857	86.0/30	1.161
51.8/11	0.640	69.8/21	0.884	87.8/31	1.196
53.6/12	0.661	71.6/22	0.912	89.6/32	1.232
55.4/13	0.684	73.4/23	0.941	91.4/33	1.267
57.2/14	0.707	75.2/24	0.970	93.2/34	1.304

Membrane Output Calculation Example

What is the expected GPD from a 75 GPD System at 40 psi pressure and 60°F water temperature?

$$PCF = 40 \div 60 = 0.666$$

$$TCF = 0.754 \text{ (from Table 1)}$$

$$\text{Expected GPD} = 75 \times 0.666 \times 0.754 = 37.7 \text{ GPD} \pm 15\%$$

Performance Test

The performance of a RO membrane is measured in terms of its rejection characteristics.

Important: Test the quality of the membrane once every 6 months.

Note: This procedure will require a Conductivity Meter (TS-C61).

Procedure:

1. Measure tap water conductivity. (Call it X)
2. Run the system for 15-20 minutes.
3. Rinse test instrument cell 2-3 times with RO water.
4. Measure RO water conductivity. (Call it Y).
5. Subtract RO water conductivity from tap water conductivity. $(X - Y)$
6. Divide this quantity by tap water conductivity. $(X - Y) \div X$
7. Rejection = $[(X - Y) \div X] \times 100$

* Conductivity in the above procedure could be replaced by hardness, alkalinity, nitrate, phosphate, silica etc. (Measured in ppm or mg/l).

Rejection of the RO Membrane Calculation Example

1. Tap water hardness = 150 ppm (X)
2. RO water hardness = 7 ppm (Y)
3. $X - Y = 143 \text{ ppm}$
4. $(X - Y) \div X = 143 \div 150 = 0.953$
5. Rejection = $[(X - Y) \div X] \times 100 = 0.953 \times 100 = 95.3$

Membrane Hardness Rejection = 95.3 % : Rejection rates less than 95% may indicate that the membrane should be replaced.

SYSTEM TROUBLESHOOTING GUIDE:

Product Water - Low Production Rate

Cause	Corrective Action
Plugged prefilters	Replace prefilters
Low water temperature	Heat feed water or use higher GPD membrane
Low feed pressure	Use booster pump or use higher GPD membrane
Fouled membrane	Replace membrane

Membrane Troubleshooting Guide

The following chart illustrates the procedure for determination of RO membrane performance. However, the chart represents only rough guidelines for determining performance of RO membrane. Depending on your tap water chemistry, the rejection characteristics of the membrane may vary significantly.

Method of Testing	Calculate % Rejection	Test Results	Conclusion
TDS/ Conductivity Tester	Measure feed water and RO product water TDS/ Conductivity	Is Rejection greater than 95%?	No - Replace Membrane Yes - Membrane OK
Alkalinity Test Kit	Measure feed water and RO product water Alkalinity	Is Rejection greater than 90%?	No - Replace Membrane Yes - Membrane OK
Hardness Test Kit**	Measure feed water and RO product water Hardness	Is Rejection greater than 90%?	No - Replace Membrane Yes - Membrane OK

**Caution: This test is not to be used on softened water sources.

STORAGE:

1. It is recommended that you store your RO System in a cool place when not being used.
2. Your RO System must be protected from freezing or temperatures above 100° F (38°C).

TIPS FOR LONG MEMBRANE LIFE:

1. Replace the sediment filter once every 6 months. This will prevent membrane fouling due to silt or sediment depositing on the membrane.
2. Replace the carbon block filter at least once every 6 months or when chlorine breakthrough occurs. This will ensure good membrane life and protect the membrane from chlorine damage.
3. Membrane should not be operated at lower than the recommended concentrate to purified water ratios.
4. Operating reverse osmosis systems on softened feed water greatly reduces the chances of membrane fouling.
5. Use the optional flush kit valve after each use of the system to extend membrane life up to 6 months.

CHOOSING A MOUNTING LOCATION:

When considering a location for the installation of the RO System, consider the following factors:

Light Sources

1. Most of the components of this system are plastic and are subject to damage by ultraviolet light from the sun and other sources such as metal halide lighting.
2. Algae is more likely to thrive inside the clear filter housings when exposed to bright light.
3. Avoid installing this unit in bright light or direct sunlight.

Temperature Extremes

1. The unit must be kept out of areas that are subject to freezing temperatures.
2. High temperatures greater than 113° F (45° C) must be avoided. If the unit is used outside, avoid putting the system in direct sunlight or connecting it to a garden hose that may be exposed to sunlight.

ONE YEAR LIMITED WARRANTY:

SpectraPure warrants (prorated) the performance of tested **SpectraSelect™ RO membrane elements only**, for one year from date of receipt by the buyer, providing that the loss of performance was not caused by fouling, neglect or water conditions exceeding the feed water parameters listed in the applicable product manual (refer to detailed membrane warranty information). SpectraPure will, on confirmation of loss of performance during the warranty period, credit the prorated amount of the current catalog price of the element.

SpectraPure will not pay for loss or damage caused directly or indirectly by the presence, growth, proliferation, spread or any activity of "fungus", wet or dry rot or bacteria. Such loss or damage is excluded regardless of any other cause or event that contributes concurrently or in any sequence to the loss. We will not pay for loss or damage caused by or resulting from continuous or repeated seepage or leakage of water, or the presence or condensation of humidity, moisture or vapor, that occurs over a period of 14 days or more. "Fungus" and "fungi" mean any type or form of fungus or Mycota or any byproduct or type of infestation produced by such fungus or Mycota, including but not limited to, mold, mildew, mycotoxins, spores, scents or any biogenic aerosols.

SpectraPure will not be liable for damage or wear to products caused by abnormal operating conditions, accident, abuse, misuse, unauthorized alteration, or repair, or if the product was not installed in accordance with SpectraPure's printed installation and operating conditions or damage caused by hot water, freezing, flood, fire, or acts of God.

To obtain service under this warranty, the defective system or components must be returned to SpectraPure with proof of purchase, installation date, failure date and supporting installation data. Any defective product to be returned to the factory must be sent freight prepaid; documentation supporting the warranty claim and a Return Goods Authorization (RMA) number must be included.

TERMS AND CONDITIONS OF SALE:

To obtain service under this warranty, the defective system or components must be returned to SpectraPure with proof of purchase, installation date and failure date.

Any defective product to be returned to the factory must be sent freight prepaid; documentation supporting the warranty claim and/or a Return Goods Authorization must be included, if so instructed.

SpectraPure will not be liable for any incidental or consequential damages, losses, or expenses arising from installation, use, or any other causes. There are no expressed or implied warranties, including merchantability or fitness for a particular purpose, which extend beyond those warranties described or referred to above.

Some jurisdictions do not allow the exclusion or limitation of incidental or consequential damages and some jurisdictions do not allow limitations on how long implied warranties may last. Therefore, the above limitations or exclusions may not apply to you. This warranty gives you specific legal rights and you may also have other rights which vary jurisdiction to jurisdiction.

Method of Payment: All orders will be shipped C.O.D. or require payment in advance.

SpectraPure, Inc. reserves the right to change prices without notice when necessary.