

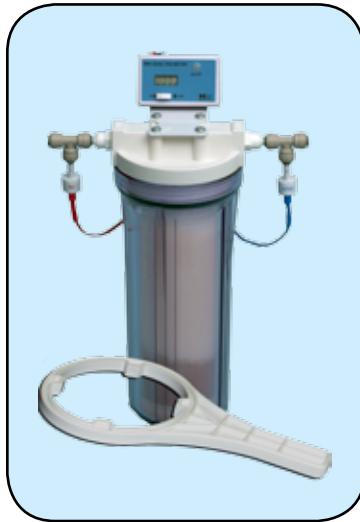

## The MAXCAP® D1 System

SpectraPure, Inc.® Revolutionary MAXCAP® DI cartridge has 3.5 times more capacity than any other Mixed-Bed or **Hi-Silica** removal deionizing cartridge. When placed upstream of your existing DI cartridge, the life of your downstream DI cartridge will increase significantly! This incredible breakthrough in DI cartridge technology will reduce your costs to produce DI water by over 50%.



### INSTALLATION AND OPERATING MANUAL



**Warning:** SpectraPure does not recommend drinking deionized water.

## TABLE OF CONTENTS

FREQUENTLY ASKED QUESTIONS .....	3
INSTALLATION .....	4-5
SPECIFICATIONS .....	6
TERMS AND CONDITIONS .....	7
.WARRANTY .....	8

**APPLICATION NOTES:** In many applications, the MaxCap DI™ can be used as a “roughing” cartridge when installed upstream of a Mixed-Bed or **Hi-Silica** removal cartridge. For example, if the RO water entering the MaxCap® DI cartridge has 20 ppm TDS (Total Dissolved Solids), the original DI cartridge might process about 400 gallons of pure DI water. By placing a MaxCap® DI cartridge in front of the original cartridge **1200 gallons** of water will pass through both cartridges before the MaxCap® DI is exhausted. The original DI cartridge will be only one-third exhausted. A second MaxCap® DI cartridge will process another **1200 gallons** and the original cartridge will now be two-thirds exhausted. Only after a third MaxCap® DI cartridge processes another **1200 gallons** will the original cartridge finally become fully exhausted.

This example illustrates that **three MaxCap® DI cartridges plus the original mixed-bed cartridge** will process 3600 gallons of pure DI water. It would have taken **nine** original mixed-bed cartridges to produce the same amount of pure DI water.

COPYRIGHT 2002-2015© BY SPECTRAPURE INC  
ALL RIGHTS RESERVED

No part of this publication may be reproduced, stored in a retrieval system, or transmitted in any form or by any means, electronic, mechanical, photocopying, recording or otherwise without the prior written permission of SpectraPure Inc.

## FREQUENTLY ASKED QUESTIONS

### WHAT IS IT USED FOR?

To extend the life of standard Mixed-Bed or High-Silica removal DI cartridge. (RO feed water only)

### HOW LONG DOES IT LAST?

Over 3 times longer than a standard Mixed-Bed or High-Silica removal DI cartridge.

### WHAT DOES THE METER DO?

It determines when the MaxCap® DI cartridge is exhausted. When the output TDS exceeds 75% of the input TDS, it is time to change the MaxCap® DI cartridge.

### HOW MUCH WILL I SAVE IF I USE THIS IN MY SYSTEM?

At least 50% water production cost savings over standard DI cartridge systems.

### CAN I USE IT ON MY EXISTING SYSTEM?

Yes. Any system using standard 2.5" x 10" DI cartridges can benefit.

### DO I NEED TO BUY A NEW SYSTEM TO USE IT?

No.

## REPLACEMENT COMPONENTS

NAME	MODEL #
MaxCap® DI	DI-MC-10

## INSTALLATION

1. Replace your original DI cartridge with the new MaxCap® D1 cartridge.
2. Cut the tubing leading to the MaxCap® DI cartridge and insert the "IN" tee of the TDS meter.
3. Cut the Tubing leaving the MaxCap® DI cartridge and insert the "OUT" tee of the TDS meter.
4. Line up the dots on both probes and position the tees with the probes hanging down.
5. Mount the meter body with velcro provided. The meter may be positioned anywhere convenient for viewing.
6. Locate the tubing after the "OUT" tee, (which is after your original D1 housing now containing the MaxCap®) and turn the feed water on. Rinse the MaxCap® DI into a bucket or down the drain until the "OUT" TDS reading is zero.

**IMPORTANT:** During the initial rinse up of the MaxCap® DI cartridge, a large ionic load is presented to the downstream DI cartridges. **Be sure to rinse up the new MaxCap® DI cartridge with the downstream cartridge removed.** This rinsing step will ensure that the MaxCap® DI cartridge is initially rinsed up to produce high quality water before connecting your downstream cartridge. Failure to rinse this upstream MaxCap® DI cartridge may reduce the lifetime of your downstream DI cartridge.

7. Connect the tubing leaving the "OUT" tee to the input of the new DI housing. (Mounting bracket provided)
8. Install your original DI cartridge into the new housing and rinse it up into the bucket prior to connecting to your application.

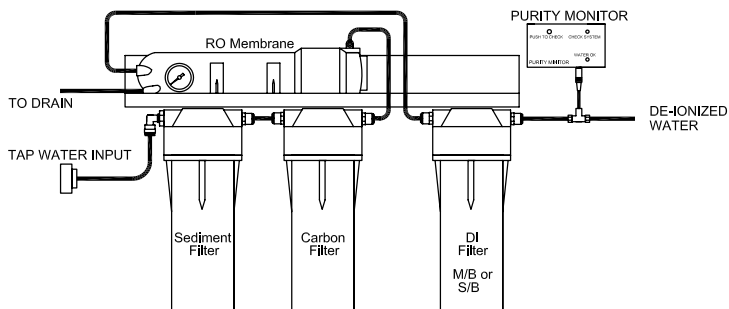

TYPICAL 4-STAGE RO/DI SYSTEM

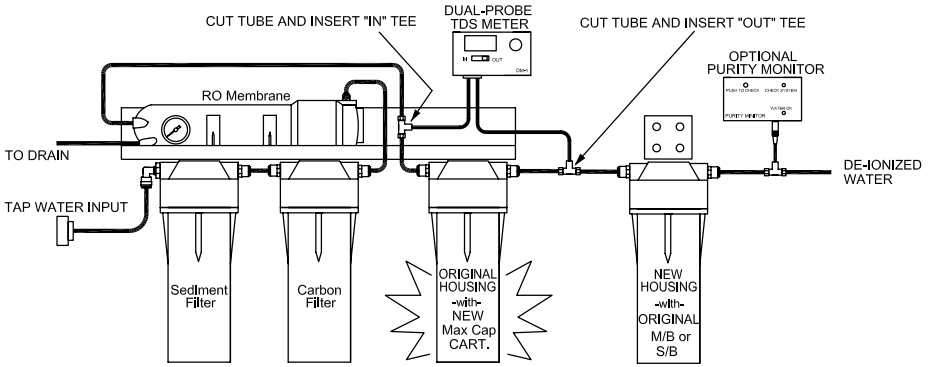

## 4-STAGE RO/DI WITH MaxCap® D1™ ADDED

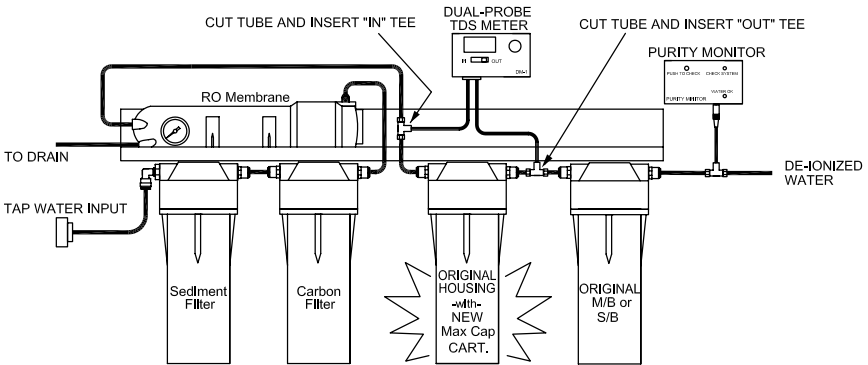

## 5-STAGE SP2000 RO/DI WITH MaxCap® D1™ INCLUDED

NOTE: In place of the optional purity monitor, we recommend the COM-100 by HM Digital™.

## TDS METER SPECIFICATIONS

RANGE:	0-9990 ppm
RESOLUTION:	1 ppm (0-999 ppm); 10 ppm (1000-9990 ppm, indicated by a blinking "x10" image)
ACCURACY:	Plus or minus 2% full scale
PROBE:	1/4" sensor with 24" (60cm) cables
FITTINGS:	Standard with 1/4" John Guest T-Fittings (also available with 3/8" or 1/2" fittings)
POWER SOURCE:	2 x 1.5v button cell batteries (LR44 or equivalent)
BATTERY LIFE:	Approx. 1000 hours of use
SIZE:	7.6 x 2 x 4.7 cm 3 x .8 x 1.9 in
WEIGHT:	79.4 g 2.8 oz

## TDS METER WARRANTY

WHAT IS COVERED	This product is warranted to the purchaser against material and workmanship for three (3) years from the date of purchase.
WHAT IS NOT COVERED	Transportation charges to the company. Included T-fittings, maintenance, see operating instructions and precautions. Any other consequential damages, incidental damages, or incidental expenses, including damages to property. Some states do not allow the exclusive or limitation of incidental or consequential damages.
HOW TO OBTAIN WARRANTY PERFORMANCE	Attach to the product your name, address, description of problem, phone number and proof of purchase with date. Package and return to:  HM DIGITAL, INC 5819 Uplander Way Culver City, CA 90230

## TERMS AND CONDITIONS OF SALE

1. Shipping charges on units or parts submitted to our facility for repair or replacement must be borne by the registered purchaser. After repair or replacement, the factory will return the unit or part freight prepaid to the customer.
2. We assume no warranty liability in connection with our equipment other than as herein specified.
3. This warranty is in lieu of all other warranties expressed or implied, including warranties of fitness for a particular purpose.
4. We do not authorize any person or representative to assume for us any other obligation on the sale of our equipment. This is the exclusive remedy and liability for consequential damages under any and all warranties which are excluded to the extent exclusion is permitted by law.
5. Proof of original purchase date must accompany all warranty claims.
6. SpectraPure, Inc. reserves the right to change prices without notice when necessary. All prices in the catalog are quoted in US dollars.
7. Claims for error in quantity or condition must be made within 10 days of receipt of material. SpectraPure, Inc. will not be responsible for any claimed shortages not reported within 10 days. Returns other than warranty claims may be subject to 20% restocking fee.
8. SpectraPure, Inc. cannot be held liable for damage or loss to a shipment by a freight carrier. Check shipment for damage before acceptance or note on freight bill subject to inspection for concealed damage. Consignee must file claim. SpectraPure, Inc. will offer as much assistance as possible.
9. A complete credit check is required prior to shipping on a Net 30 or "C.O.D. - CUSTOMER CHECK ACCEPTABLE" basis. In the interim period during which credit references are being evaluated, all orders must be shipped "C.O.D. - CERTIFIED FUNDS" (cash, cashiers check or money order).
10. All returned checks (due to insufficient funds or closed accounts) will be subjected to a **\$25 service charge**.
11. Invoices on Net 30 accounts not paid within 30 days of shipment will be considered delinquent and will accrue Finance charges at the rate of 1.5% per month (18% per annum).

## THREE YEAR LIMITED WARRANTY

SpectraPure, Inc.® warrants the product to the original owner only to be free of defects in material and workmanship for a period of three years from the date of receipt. SpectraPure's liability under this warranty shall be limited to repairing or replacing at SpectraPure's option, without charge, F.O.B. SpectraPure's factory, any product of SpectraPure's manufacture. SpectraPure will not be liable for any cost of removal, installation, transportation or any other charges which may arise in connection with a warranty claim. Products which are sold but not manufactured by SpectraPure are subject to the warranty provided by the manufacturer of said products and not by SpectraPure's warranty. SpectraPure will not be liable for damage or wear to products caused by abnormal operating conditions, accident, abuse, misuse, unauthorized alteration or repair or, if the product was not installed in accordance with SpectraPure's or other manufacturer's printed installation and operating conditions, or damage caused by hot water, freezing, flood, fire or acts of God.

SpectraPure will not be responsible for any consequential damages arising from installation or use of the product, including any water or mold damage due to flooding which may occur due to malfunction or faulty installation, including, but not limited to failure by installer to over- or under-tighten fittings, housings, and/or push-style fittings, or improper installation of push-style fittings. Consumable items such as prefilters and membranes are not covered under the 3 year warranty.

SpectraPure warrants (prorated) the performance of tested SpectraSelectPlus™ RO membrane elements only, for one year from date of receipt by the buyer, providing that the loss of performance was not caused by fouling, neglect or water conditions exceeding the feed water parameters listed in the applicable product manual (refer to detailed membrane warranty information). SpectraPure will, on confirmation of loss of performance during the warranty period, credit the prorated amount of the current catalog price of the element. The disposable filters and cartridges are not covered under the warranty.

To obtain service under this warranty, the defective system or components must be returned to SpectraPure with proof of purchase, installation date, failure date and supporting installation data. Any defective product to be returned to the factory must be sent freight prepaid; documentation supporting the warranty claim and a Return Merchandise Authorization (RMA) number must be included. SpectraPure will not be liable for shipping damages due to the improper packaging of the returned equipment and all returned goods must also have adequate insurance coverage and a tracking number.

SpectraPure will not pay for loss or damage caused directly or indirectly by the presence, growth, proliferation, spread or any activity of "fungus", wet or dry rot or bacteria. Such loss or damage is excluded regardless of any other cause or event that contributes concurrently or in any sequence to the loss. We will not pay for loss or damage caused by or resulting from continuous or repeated seepage or leakage of water, or the presence or condensation of humidity, moisture or vapor, that occurs over a period of 14 days or more. "Fungus" and "fungi" mean any type or form of fungus or Mycota or any byproduct or type of infestation produced by such fungus or Mycota, including but not limited to, mold, mildew, mycotoxins, spores, scents or any biogenic aerosols.

SpectraPure will not be liable for any incidental or consequential damages, losses or expenses arising from installation, use, or any other causes. There are no expressed or implied warranties, including merchantability or fitness for a particular purpose, which extend beyond those warranties described or referred to above.

**\*The three year limited warranty does not apply to consumable items, including but not limited to, filters and cartridges unless specifically stated above**